



AXIAL FANS

Axis / Turbo



OPERATION MANUAL

CONTENT

3	Introduction
3	General
3	Safety rules
3	Transport and storage requirements
3	Manufacturer's warranty
4	Fan design
4	Delivery set
4	Modifications and options
5	Technical data
10	Mounting and operation guidelines
11	Mounting sequence
11	Installation and connection to power mains
13	Maintenance
14	Warranty card

BLAUBERG Company is happy to offer your attention the new high-quality axial fans Blaubeerg Axis and Blaubeerg Tubo. The solid team of high-qualified professionals with many years of working experience, technological innovations in design and production, high-quality components and materials from the top worldwide producers have become the precondition for the best fan in its class.

INTRODUCTION

The present operation manual contains technical description, technical data sheets, operation and mounting guidelines, safety precautions and warnings for safe and correct operation of the fan.

GENERAL

The axial fans Axis, Tubo are not a ready for use product. It is a component unit designed for integration into air conditioning and ventilation systems.

The fans Axis-Q, Axis-QR, Axis-QA, Axis-QRA are designed for direct air exhaust. The models Axis-F are designed for connection to Ø 205 mm up to 645 mm air ducts and the models Tubo-M, Tubo-MZ are designed for connection to Ø 160 mm up to 315 mm air ducts.

The fan has IEC Protection Class I and must be grounded.

The fans are allowed for operation only after final mounting, that includes installation of protecting devices in compliance with DIN EN ISO 13875 (DIN EN ISO 12100) as well as other construction safety equipment.

The fan design is regularly improved, so some models can slightly differ from those ones described in this service instruction.

SAFETY RULES

The fan complies with the requirements according to the EU norms and directives, to the relevant EU-Low Voltage Equipment Directives, EU-Directives on Electromagnetic Compatibility.

All operations related to the fan electrical connections, servicing and repair works are allowed only after the fan disconnection from power mains.

All mounting and servicing operations are allowed for duly qualified electricians with valid electrical work permit for electric operations at the units up to 1000 V after careful study of the present user's manual.

Please follow the safety regulations and working instructions (DIN EN 50 110, IEC 364).

Make sure the impeller and the casing are not damaged before connecting the fan to power mains. The casing internals must be free of any foreign objects which can damage the impeller blades.

Disconnect the fan from power mains prior to any operations related to the fan servicing and repair works.

Take measures to prevent contact with the fan to avoid physical damages during the fan step and start-up.

Misuse of the product or any unauthorized modification are not allowed.

The fan is designed for connection to ac single-phase or ac three-phase power mains, see "Technical Data". The fan is rated for permanent operation during non-stop power supply.

Take steps to prevent ingress of smoke, carbon monoxide and other combustion products into the room through open chimney flues or other fire-protection devices. Sufficient air supply must be provided for proper combustion and exhaust of gases through the chimney of fuel burning

equipment to prevent back drafting. The maximum permitted pressure difference per living units is 4 Pa.

The transported air must not contain any dust or other solid impurities, sticky substances or fibrous materials.

The fan is not designed for use in an inflammable and explosive medium.

The transported medium must not have an aggressive effect on steel at the temperature stated in the tables 1, 3, 5, 7 of the section "Technical data".

Do not close or block the fan intake or exhaust vent not to disturb the normal air passage. Do not sit on the fan and do not put objects on the fan.

Follow the manual guidelines to ensure trouble-free operation and long service life of the product.

STORAGE AND TRANSPORTATION RULES

Store the delivered product in the manufacturer's original packing box in a dry ventilated premise with the ambient temperature from +5°C up to +40°C and relative humidity less than 80% at the temperature +25°C.

Store the fan in an environment with minimized risk of mechanical damages, temperature and humidity fluctuations. Store the fan inside a room or under a shelter.

Transport of the product is allowed by any vehicle in the manufacturer's original packing box. Use hoist machinery for handling and transportation to prevent possible mechanical damages of the product. Fulfil the requirements for transportation of the specified cargo type during cargo-handling operations.

Do not expose the product to extremely low or high temperatures.

MANUFACTURER'S WARRANTY

The fan complies with the requirements according to the EU norms and directives, to the relevant EU-Low Voltage Equipment Directives, EU-Directives on Electromagnetic Compatibility.

We hereby declare that the following product complies with the essential protection requirements of Electromagnetic Council Directive 2004/108/EC, 89/336/EEC and Low Voltage Directive 2006/95/EC, 73/23/EEC and CE-marking Directive 93/68/EEC on the approximation of the laws of the Member States relating to electromagnetic compatibility. This certificate is issued following test carried out on samples of the product referred to above. Assessment of compliance of the product with the requirements relating to electromagnetic compatibility was based on the following standards.

The manufacturer hereby warrants normal operation of the fan over the period of 2 years from the retail sale date provided observance of the installation and operation regulations.

In case of failure due to faulty equipment during the warranty period the consumer has the right to exchange it.

If case of no confirmation of the sale date, the warranty term shall be calculated from the manufacturing date.

The replacement is offered by the Seller.

The MANUFACTURER shall not be liable for any damage resulting from any misuse of or gross mechanic interference with the fan.

Please follow the operation guidelines always.



ATTENTION

The product is not allowed for use by children and persons with reduced physical, mental or sensory capacities, without proper practical experience or expertise, unless they are controlled or instructed on the product operation by the person(s) responsible for their safety. Supervise the children and do not let them play with the product.

WARNING



Do not dispose in domestic waste.

The unit contains in part material that can be recycled and in part substances that should not end up as domestic waste.

Dispose of the unit once it has reached the end of its working life according to the regulations valid where you are.

FAN DESIGN AXIS-Q / AXIS-QR / AXIS-QA / AXIS-QRA

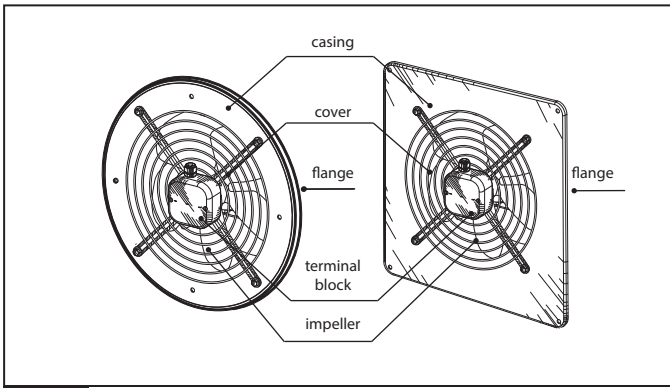

Fig. 1

DELIVERY SET

- ✓ fan - 1 item;
- ✓ operation manual.

MODIFICATIONS AND OPTIONS

- AXIS-Q**
Fan with a square mounting plate
- AXIS-QR**
Fan with a round mounting plate

FAN DESIGN AXIS-F

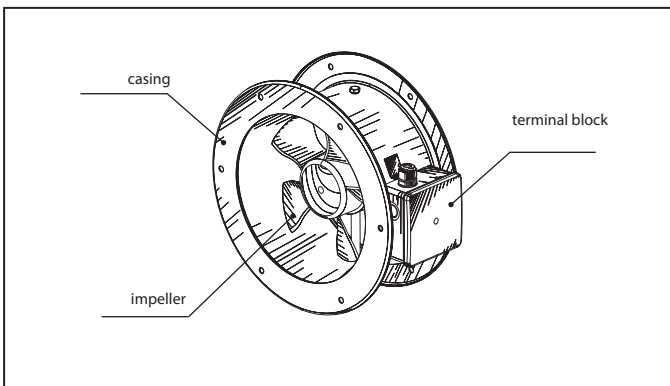

Fig. 2

DELIVERY SET

- ✓ fan - 1 item;
- ✓ operation manual.

FAN DESIGN TUBO-M / TUBO-MZ

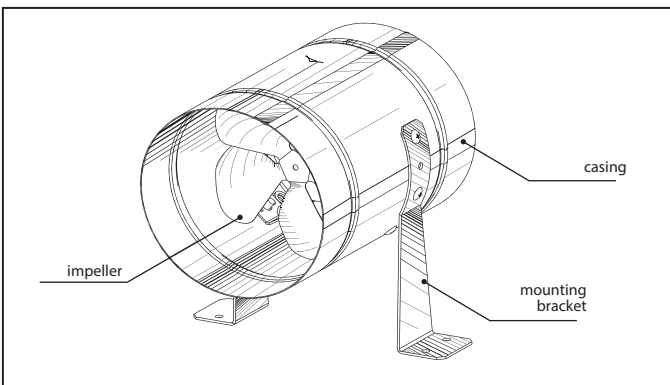

Fig. 3

DELIVERY SET

- ✓ fan - 1 item;
- ✓ screws and dowels - 4 items;
- ✓ mounting brackets - 2 items;
- ✓ operation manual.

MODIFICATIONS AND OPTIONS

- TUBO-M**
Fan made of polymer coated steel
- TUBO-MZ**
Fan made of galvanized steel

TECHNICAL DATA AXIS-Q / AXIS-QR

Table 1. Technical data

Parameters	Axis-Q 200 2E	Axis-Q 250 2E	Axis-Q 250 4E	Axis-Q 300 2E	Axis-Q 300 4E	Axis-Q 350 4E	Axis-Q 400 4E
	Axis-QR 200 2E	Axis-QR 250 2E	Axis-QR 250 4E	Axis-QR 300 2E	Axis-QR 300 4E	Axis-QR 350 4E	Axis-QR 400 4E
Voltage, 50 Hz [V]	230	230	230	230	230	230	230
Power [W]	55	80	50	145	75	140	180
Current [A]	0,26	0,4	0,22	0,66	0,35	0,65	0,82
Max. air flow [m ³ /h]	860	1050	800	2230	1340	2500	3580
RPM [min ⁻¹]	2300	2400	1380	2300	1350	1380	1380
Noise level, 3 m [dBA]**	50	60	55	60	58	62	63
Max. transported air temperature [°C]	-30 +60	-30 +60	-30 +60	-30 +60	-30 +60	-30 +60	-30 +60
Ingress Protection Rating	IP 24	IP 24	IP 24	IP 24	IP 24	IP X4	IP 24

Parameters	Axis-Q 450 4E	Axis-Q 500 4E	Axis-Q 550 4E	Axis-Q 630 4E	Axis-Q 630 6E	Axis-Q 250 2D	Axis-Q 250 4D
	Axis-QR 450 4E	Axis-QR 500 4E	Axis-QR 550 4E	Axis-QR 630 4E	Axis-QR 630 6E	Axis-QR 250 2D	Axis-QR 250 4D
Voltage, 50 Hz [V]	230	230	230	230	230	400	400
Power [W]	250	420	550	750	540	80	60
Current [A]	1.2	1.95	2.55	3.5	2.4	0.22	0.17
Max. air flow [m ³ /h]	4680	7060	8800	11900	10900	1060	850
RPM [min ⁻¹]	1350	1300	1300	1360	850	2600	1400
Noise level, 3 m [dBA]**	64	69	70	75	72	60	55
Max. transported air temperature [°C]	-30 +60	-30 +60	-30 +60	-30 +60	-30 +60	-30 +60	-30 +60
Ingress Protection Rating	IP 24	IP 24	IP 24	IP 24	IP 24	IP 24	IP 24

Parameters	Axis-Q 300 2D	Axis-Q 300 4D	Axis-Q 350 4D	Axis-Q 400 4D	Axis-Q 450 4D	Axis-Q 500 4D	Axis-Q 550 4D	Axis-Q 630 4D
	Axis-QR 300 2D	Axis-QR 300 4D	Axis-QR 350 4D	Axis-QR 400 4D	Axis-QR 450 4D	Axis-QR 500 4D	Axis-QR 550 4D	Axis-QR 630 4D
Voltage, 50 Hz [V]	400	400	400	400	400	400	400	400
Power [W]	145	75	140	180	250	450	750	800
Current [A]	0.25	0.22	0.38	0.47	0.6	0.9	1.5	1.6
Max. air flow [m ³ /h]	2310	1310	2520	3740	5280	6570	9700	12200
RPM [min ⁻¹]	2350	1380	1380	1380	1360	1300	1350	1320
Noise level, 3 m [dBA]**	60	58	62	64	65	72	73	78
Max. transported air temperature [°C]	-30 +60	-30 +60	-30 +60	-30 +60	-30 +60	-30 +60	-30 +60	-30 +60
Ingress Protection Rating	IP 24	IP 24	IP 24	IP 24	IP 24	IP 24	IP 24	IP 24

* Allowable deviation of the rated voltage: ±10%

**Noise level is measured at 3 m distance from the fan connected to the air ducts, in free space.

Table 2. Overall dimensions

Type	Dimensions [mm]					Weight [kg]
	ØD	Ød	B	B1	L	
Axis-Q 200 2E	210	7	312	260	145	3.95
Axis-Q 250 2E	260	7	370	320	155	4.17
Axis-Q 250 4E	260	7	370	320	155	4.06
Axis-Q 300 2E	326	9	430	380	195	5.27
Axis-Q 300 4E	326	9	430	380	195	5.11
Axis-Q 350 4E	388	9	485	435	200	7.05
Axis-Q 400 4E	417	9	540	490	240	8.8
Axis-Q 450 4E	465	11	576	535	250	10.5
Axis-Q 500 4E	520	11	655	615	260	14.15
Axis-Q 550 4E	570	11	725	675	280	16.5
Axis-Q 630 4E	650	11	800	710	295	22.55
Axis-Q 630 6E	650	11	800	710	295	22.55
Axis-Q 250 2D	260	7	370	320	155	4.17
Axis-Q 250 4D	260	7	370	320	155	4.06
Axis-Q 300 2D	326	9	430	380	155	5.27
Axis-Q 300 4D	326	9	430	380	155	5.11
Axis-Q 350 4D	388	9	485	435	200	7.05
Axis-Q 400 4D	417	9	540	490	240	8.8
Axis-Q 450 4D	465	11	576	535	250	10.5
Axis-Q 500 4D	520	11	655	615	260	14.15
Axis-Q 550 4D	570	11	725	675	280	16.5
Axis-Q 630 4D	650	11	800	710	295	22.55

Type	Dimensions [mm]					Weight [kg]
	ØD	Ød	B1	B2	L	
Axis-QR 200 2E	210	7	250	280	145	2.45
Axis-QR 250 2E	260	7	295	320	155	3.38
Axis-QR 250 4E	260	7	295	320	155	3.38
Axis-QR 300 2E	326	9	380	397	195	4.44
Axis-QR 300 4E	326	9	380	397	195	4.66
Axis-QR 350 4E	388	9	442	460	200	6.33
Axis-QR 400 4E	417	9	504	528	240	8.27
Axis-QR 450 4E	465	11	578	607	250	9.77
Axis-QR 500 4E	520	11	590	655	260	12.2
Axis-QR 550 4E	570	11	645	710	280	14.95
Axis-QR 630 4E	650	11	760	800	295	20.83
Axis-QR 630 4E	650	11	760	800	295	20.83
Axis-QR 250 2D	260	7	295	320	155	3.38
Axis-QR 250 4D	260	7	295	320	155	3.38
Axis-QR 300 2D	326	9	380	397	155	4.44
Axis-QR 300 4D	326	9	380	397	155	4.66
Axis-QR 350 4D	388	9	442	460	200	6.33
Axis-QR 400 4D	417	9	504	528	240	8.27
Axis-QR 450 4D	465	11	578	607	250	9.77
Axis-QR 500 4D	520	11	590	655	260	12.2
Axis-QR 550 4D	570	11	645	710	280	14.95
Axis-QR 630 4D	650	11	760	800	295	20.83

TECHNICAL DATA AXIS-F

Table 3. Technical data

Parameters	Axis-F 200 2E	Axis-F 250 2E	Axis-F 250 4E	Axis-F 300 2E	Axis-F 300 4E	Axis-F 350 4E
Voltage, 50 Hz [V]	230	230	230	230	230	230
Power [W]	55	80	50	145	75	140
Current [A]	0,26	0,4	0,22	0,66	0,35	0,65
Max. air flow [m³/h]	860	1050	800	2230	1340	2500
RPM [min ⁻¹]	2300	2400	1380	2300	1350	1380
Noise level, 3 m [dBA]**	50	60	55	60	58	62
Max. transported air temperature [°C]	-30 +60	-30 +60	-30 +60	-30 +60	-30 +60	-30 +60
Ingress Protection Rating	IP X4	IP X4	IP X4	IP X4	IP X4	IP X4

Parameters	Axis-F 400 4E	Axis-F 450 4E	Axis-F 500 4E	Axis-F 550 4E	Axis-F 630 4E	Axis-F 250 2D
Voltage, 50 Hz [V]	230	230	230	230	230	400
Power [W]	180	25-0	420	550	750	80
Current [A]	0.82	1.2	1.95	2.55	3.5	0.22
Max. air flow [m³/h]	3580	4680	7060	8800	11900	1060
RPM [min ⁻¹]	1380	1350	1300	1300	1360	2600
Noise level, 3 m [dBA]**	63	64	69	70	75	60
Max. transported air temperature [°C]	-30 +60	-30 +60	-30 +60	-30 +60	-30 +60	-30 +60
Ingress Protection Rating	IP X4	IP X4	IP X4	IP X4	IP X4	IP X4

Table 3. Technical data

Parameters	Axis-F 250 4D	Axis-F 300 2D	Axis-F 300 4D	Axis-F 350 4D	Axis-F 400 4D	Axis-F 450 4D
Voltage, 50 Hz [V]	400	400	400	400	400	400
Power [W]	60	145	75	140	180	250
Current [A]	0.17	0.25	0.22	0.38	0.47	0.6
Max. air flow [m ³ /h]	850	2310	1310	2520	3740	5280
RPM [min ⁻¹]	1400	2350	1380	1380	1380	1360
Noise level, 3 m [dBA]**	55	60	58	62	64	65
Max. transported air temperature [°C]	-30 +60	-30 +60	-30 +60	-30 +60	-30 +60	-30 +60
Ingress Protection Rating	IP X4	IP X4	IP X4	IP X4	IP X4	IP X4

* Allowable deviation of the rated voltage: ±10%

**Noise level is measured at 3 m distance from the fan connected to the air ducts, in free space.

Table 4. Overall dimensions

Type	Dimensions [mm]						Weight [kg]
	ØD	ØD1	ØD1	Ød	B	L	
Axis-F 200 2E	205	235	255	7	290	120	3.0
Axis-F 250 2E	260	286	306	7	340	150	3.9
Axis-F 250 4E	260	286	306	7	340	150	4.0
Axis-F 300 2E	310	356	382	7	410	160	6.2
Axis-F 300 4E	310	356	382	7	410	160	6.2
Axis-F 350 4E	362	395	421	9.5	450	160	7.7
Axis-F 400 4E	412	438	465	9.5	500	170	8.1
Axis-F 450 4E	462	487	515	9.5	550	200	9.1
Axis-F 500 4E	515	541	570	9.5	600	220	11.0
Axis-F 550 4E	565	605	636	11.5	660	230	13.9
Axis-F 630 4E	645	674	715	11.5	740	250	16.4
Axis-F 250 2D	260	286	306	7	340	150	3.9
Axis-F 250 4D	260	286	306	7	340	150	4.0
Axis-F 300 2D	310	356	382	7	410	160	5.7
Axis-F 300 4D	310	356	382	7	410	160	5.7
Axis-F 350 4D	362	395	421	9.5	450	160	7.7
Axis-F 400 4D	412	438	465	9.5	500	170	8.1
Axis-F 450 4D	462	487	515	9.5	550	200	9.1

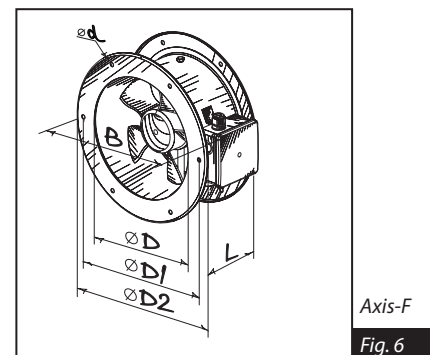
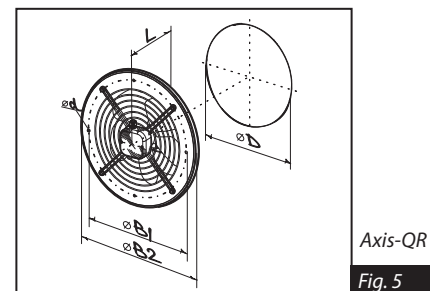
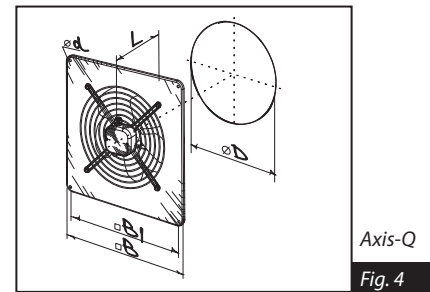

TECHNICAL DATA AXIS-QA / AXIS-QRA

Table 5. Technical data

Parameters	Axis-QA 150	Axis-QA 200	Axis-QA 250	Axis-QA 315
	Axis-QRA 150	Axis-QRA 200	Axis-QRA 250	Axis-QRA 315
Voltage, 50 Hz [V]	230	230	230	230
Power [W]	36	43	68	110
Current [A]	0.26	0.28	0.48	0.75
Max. air flow [m ³ /h]	200	405	1070	1700
RPM [min ⁻¹]	1300	1300	1300	1300
Noise level, 3 m [dBA]**	33	32	48	54
Max. transported air temperature [°C]	+40	+40	+40	+40
Ingress Protection Rating	IP 24	IP 24	IP 24	IP 24

* Allowable deviation of the rated voltage: ±10%

**Noise level is measured at 3 m distance from the fan connected to the air ducts, in free space.

Table 6. Overall dimensions

Type	Dimensions [mm]					Weight [kg]
	ØD	Ød	B	B1	L	
Axis-QA 150	162	7	250	210	120	2.1
Axis-QA 200	208	7	312	260	120	2.82
Axis-QA 250	262	7	370	320	140	4.88
Axis-QA 315	312	9	430	380	170	5.46

Type	Dimensions [mm]					Weight [kg]
	Ø	ØD1	ØD2	Ød	L	
Axis-QRA 150	162	191	220	7	120	1.91
Axis-QRA 200	208	270	300	7	120	2.5
Axis-QRA 250	262	330	360	7	140	4.1
Axis-QRA 315	312	390	420	9	170	5.24

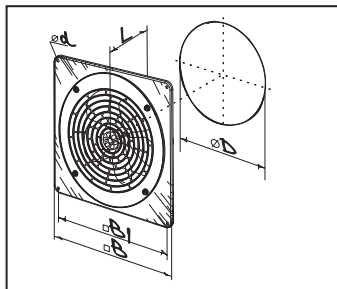

Fig. 7

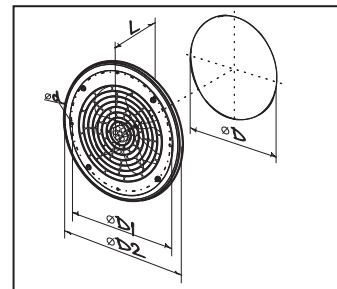

Fig. 8

TECHNICAL DATA TUBO-M / TUBO-MZ

Table 7. Technical data

Parameters	Tubo-M 150	Tubo-M 200	Tubo-M 250	Tubo-M 315
	Tubo-MZ 150	Tubo-MZ 200	Tubo-MZ 250	Tubo-MZ 315
Voltage, 50 Hz [V]	230	230	230	230
Power [W]	36	43	68	110
Current [A]	0.26	0.28	0.48	0.75
Max. air flow [m ³ /h]	200	405	1070	1700
RPM [min ⁻¹]	1300	1300	1300	1300
Noise level, 3 m [dBA]**	33	32	48	54
Max. transported air temperature [°C]	+40	+40	+40	+40
Ingress Protection Rating	IP X4	IP X4	IP X4	IP X4

* Allowable deviation of the rated voltage:
±10%

**Noise level is measured at 3 m distance
from the fan connected to the air ducts,
in free space.

Table 8. Overall dimensions

Type	Dimensions [mm]					Weight [kg]
	ØD	B	L	L1	L3	
Tubo-M 150 / Tubo-MZ 150	162	183	220	40	30	2.08
Tubo-M 200 / Tubo-MZ 200	208	228	220	40	30	2.54
Tubo-M 250 / Tubo-MZ 250	262	283	270	55	30	3.97
Tubo-M 315 / Tubo-MZ 315	315	337	278		40	4.84

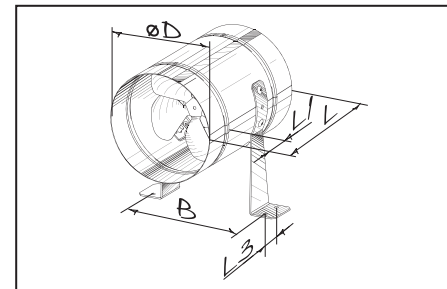

Fig. 9

MOUNTING AND OPERATION GUIDELINES

The air motion direction in the system must match the pointer on the fan casing.

Install the fan to ensure sufficient and quick access for servicing and repair operations.

The fan must be grounded.

While mounting protect the fan against water ingress in the following way:

1. Install an outer hood above in case of vertical mounting position, fig. 10.

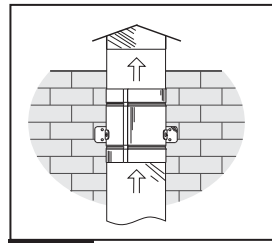

Fig. 10

MOUNTING SEQUENCE

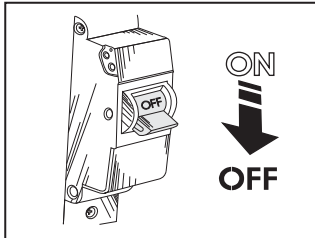

Fig. 11

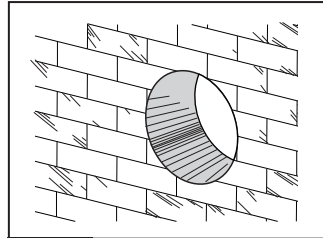

Fig. 12

AXIS-Q

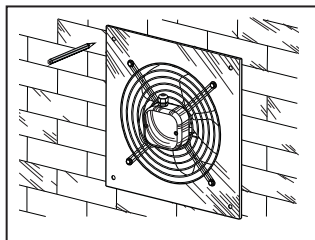

Fig. 13

AXIS-QR

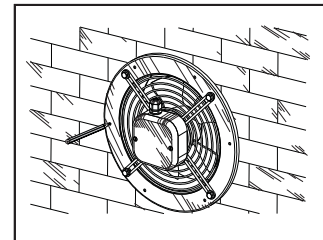

Fig. 14

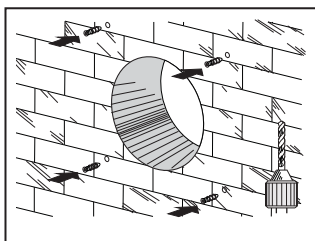

Fig. 15

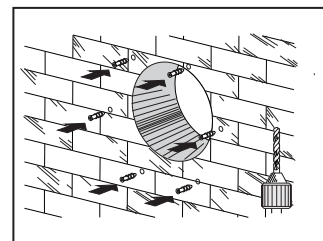

Fig. 16

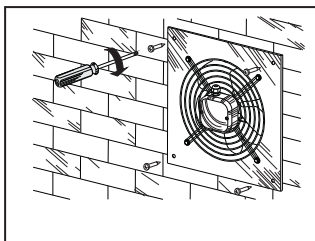

Fig. 17

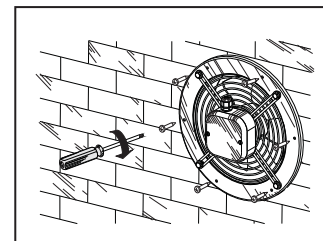

Fig. 18

AXIS-QA

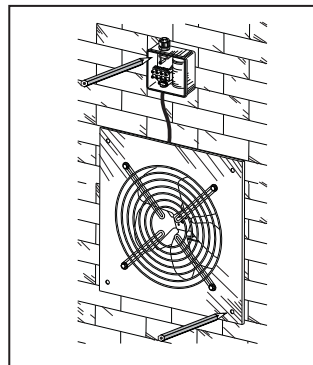

Fig. 19

AXIS-QRA

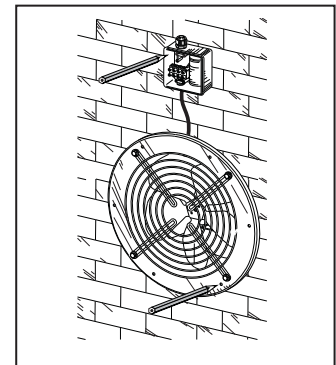

Fig. 20

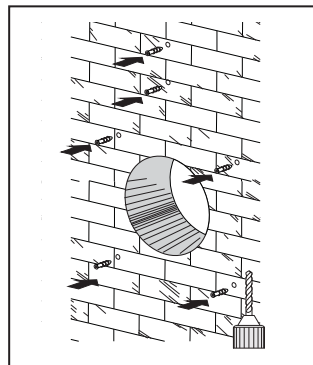

Fig. 21

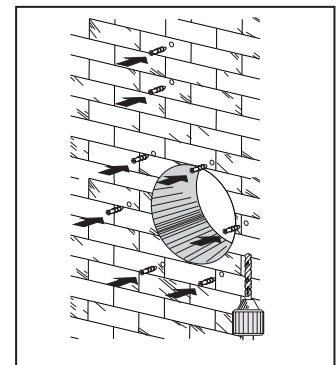

Fig. 22

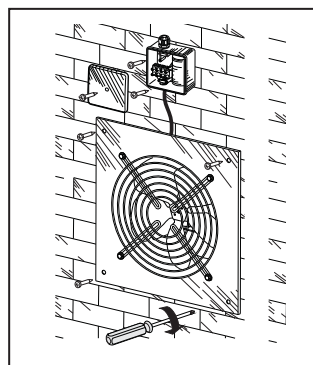

Fig. 23

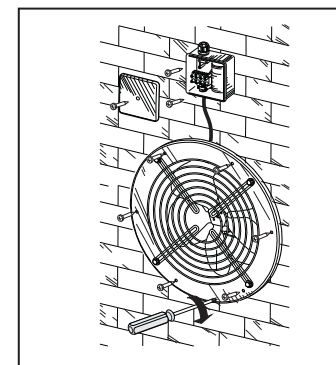

Fig. 24

**MOUNTING SEQUENCE
AXIS-F**

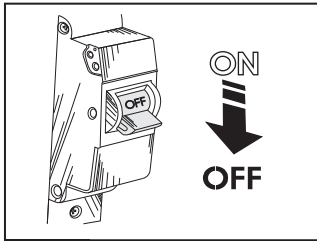

Fig. 25

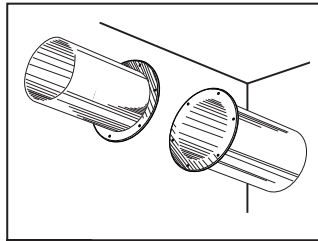

Fig. 26

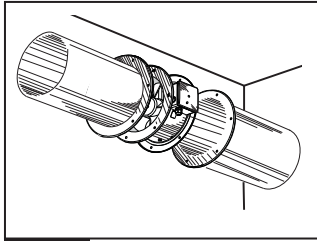

Fig. 27

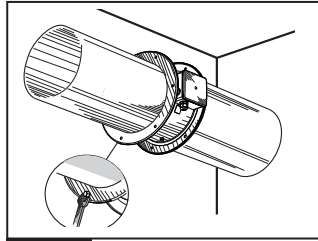

Fig. 28

**MOUNTING SEQUENCE
TUBO-M / TUBO-MZ**

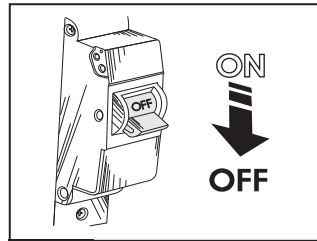

Fig. 29

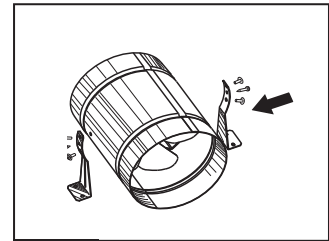

Fig. 30

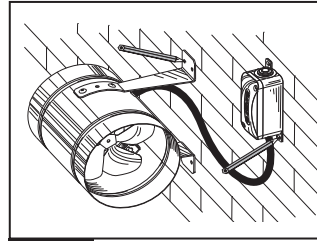

Fig. 31

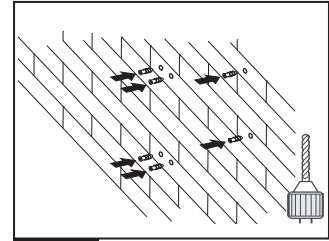

Fig. 32

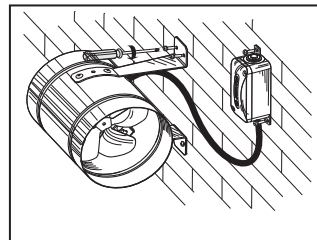

Fig. 33

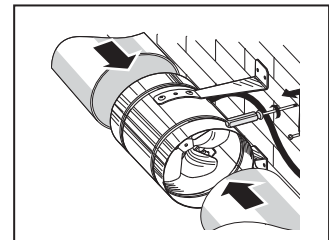

Fig. 34

INSTALLATION AND CONNECTION TO POWER MAINS

Connection of the fan to power mains is allowed by a qualified electrician only. The rated electrical parameter are stated on the rating plate.

No modifications of internal connections are allowed and will result in void warranty. Connect the fan only to power mains with valid electric standards.

The house cabling system must be equipped with an automatic switch at the external input. Connect the fan to power mains through the automatic switch.

The contact gap on all poles at least 3 mm. The automatic switch trip current must be in compliance with the fan current consumption, refer Table 1, 3, 5, 7. Install the automatic switch to ensure prompt access.

Cut power supply to the fan off by turning the automatic electric switch QF to OFF position (fig.3 5). Take steps to prevent activation of the automatic switch.

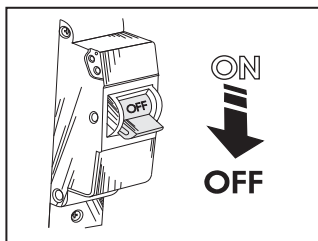

Fig. 35

The fan wiring diagram is shown in fig. 36-38.

Connection sequence of the fan, shown on fig. 39-53.

AXIS-Q

AXIS-QR

AXIS-F

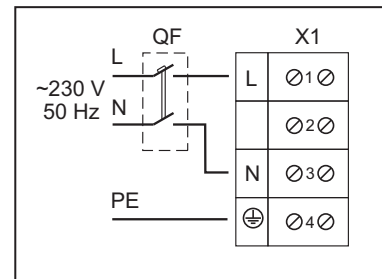

Fig. 36 Single-phase fans

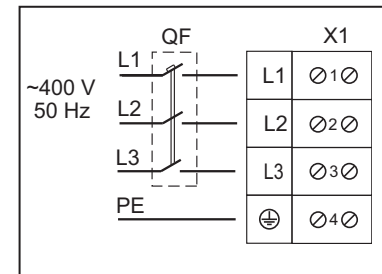

Fig. 37 Three-phase fans

AXIS-QA

AXIS-QRA

TUBO-M / TUBO-MZ

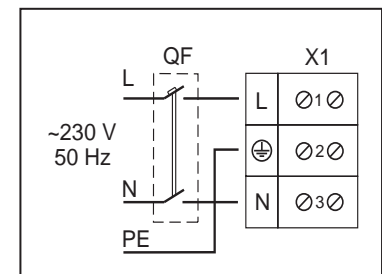

Fig. 38

INSTALLATION AND CONNECTION TO POWER MAINS

AXIS-Q

AXIS-QR

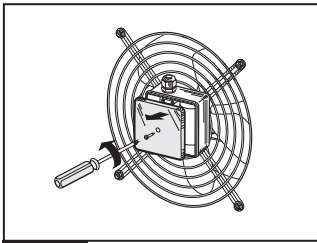

Fig. 39

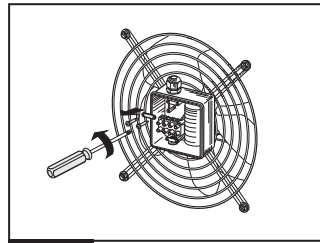

Fig. 40

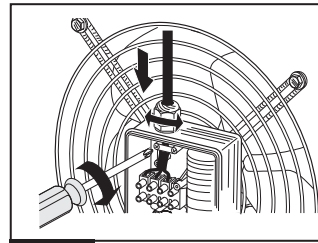

Fig. 41

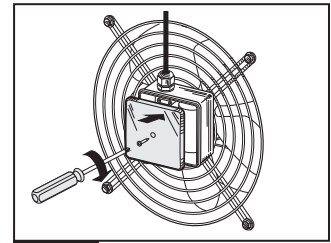

Fig. 42

AXIS-F

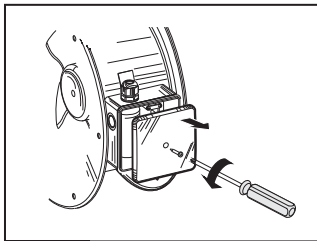

Fig. 43

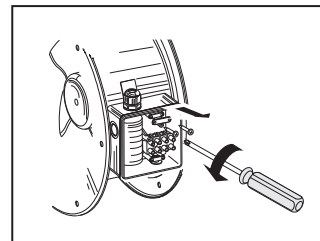

Fig. 44

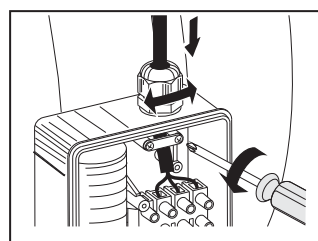

Fig. 45

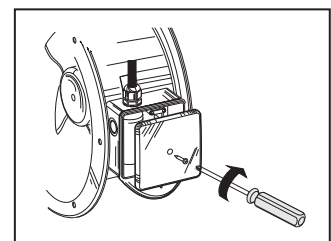

Fig. 46

AXIS-QA

AXIS-QRA

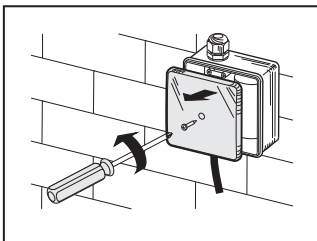

Fig. 47

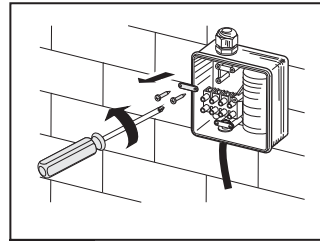

Fig. 48

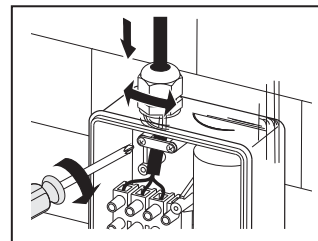

Fig. 49

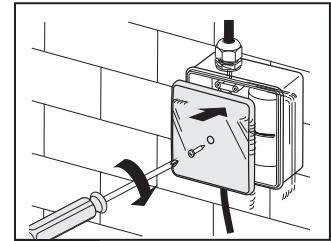

Fig. 50

TUBO-M / TUBO-MZ

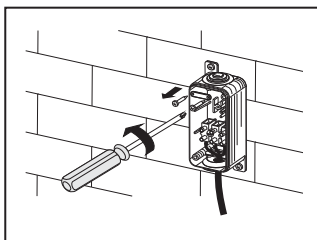

Fig. 51

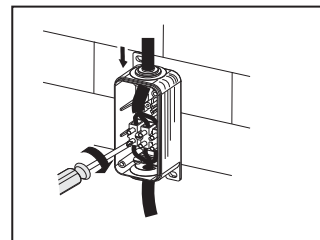

Fig. 52

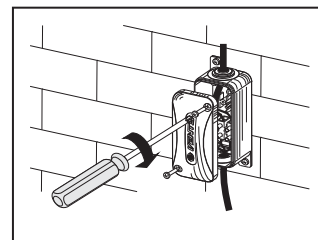

Fig. 53

MAINTENANCE

Regular technical supervision and maintenance of the fan are required to ensure the product long service life and non-stop operation.

Disconnect the fan from power mains prior to any maintenance operations, fig. 54.

Do not place the fan in water (fig.55).

Maintenance of the fan is required and means cleaning the fan surfaces from dust and dirt. Maintenance includes regular cleaning, control of the impeller, motor, impeller blades.

Mounting sequence of the fan is shown on fig. 56 - 67.

Clean the impeller blades with a soft cloth or a brush wetted in a mild soap solution. Avoid liquid splashing on the motor. Clean the impeller blades thoroughly at least once in 6 months.

Operation recommendations:

1. Clean the fan regularly from dust, dirt and foreign objects.
2. Check all fastening connections periodically.
3. Control generated noise and vibration. High vibration may indicate the bearing wear, sticking of the dirt particles contained in the transported air, the impeller blades wear, loose connection between the fan and the air duct.
4. Check periodically the fastening connections, impeller for possible blade damages, check connection of the fan to the air duct and coating.

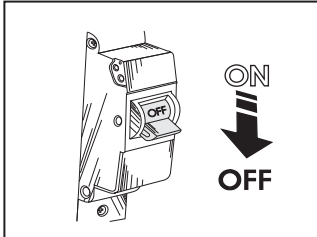

Fig. 54

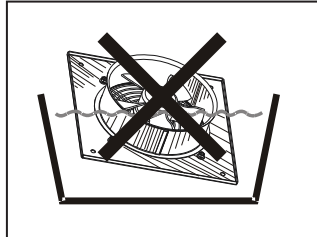

Fig. 55

AXIS-Q

AXIS-QR

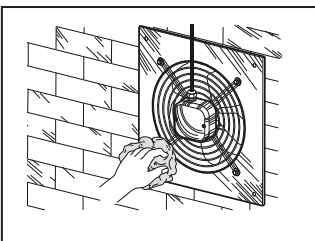

Fig. 56

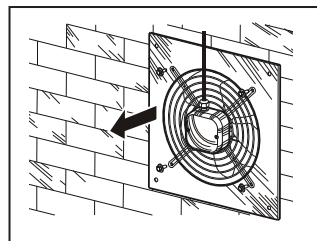

Fig. 57

AXIS-QA

AXIS-QRA

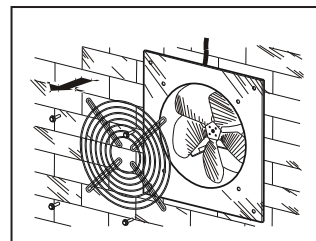

Fig. 58

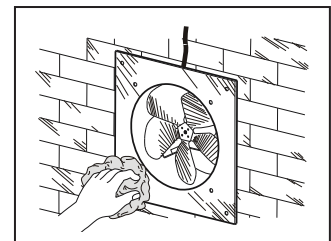

Fig. 59

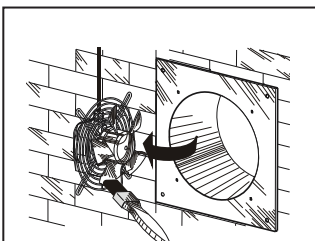

Fig. 60

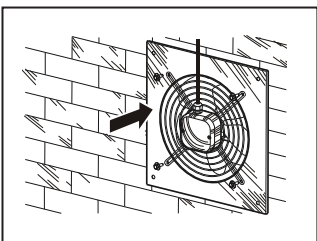

Fig. 61

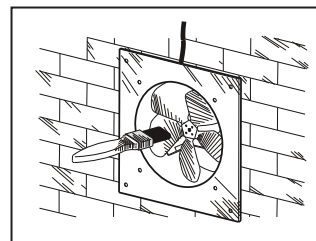

Fig. 62

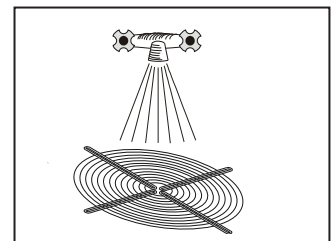

Fig. 63

AXIS-F

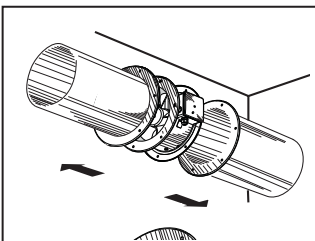

Fig. 64

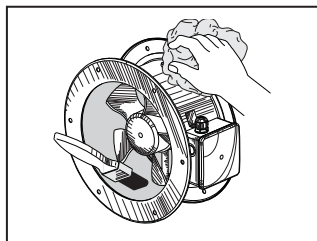

Fig. 65

TUBO-M / TUBO-MZ

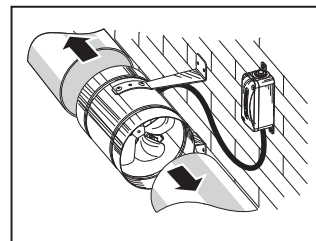

Fig. 66

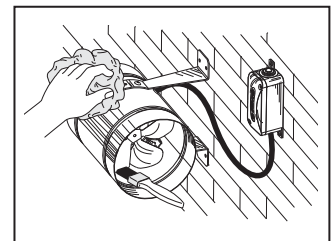

Fig. 67

WARRANTY CARD

BLAUBERG

MANUFACTURE DATE

SELLER

SALES DATE

REPRESENTATIVE IN EU

Blauberg Ventilatoren GmbH
Aidenbachstr. 52a,
D-81379 München, Germany



BLAUBERG
Ventilatoren

